

BITE 2

BITE 2P

BIDDLE® BITE® 2 and BITE 2P

- Determines condition of lead-acid and NiCd cells up to 7000 Ah
- On-board Pass/Warning/Fail indications
- Robust, repeatable instruments
- On-line testing

Battery Impedance Test Equipment

DESCRIPTION

The BIDDLE BITE 2 and BITE 2P Battery Impedance Test Equipment determine the condition of lead-acid and nickel-cadmium cells up to 7000 Ah. An advanced feature set has been developed that includes Pass/Warning/Fail calculations based on a user-entered baseline value, advanced printing functions and more. The case of the BITE 2P consists of both the transmitter and a carrying case for all of the standard accessories and some of the optional accessories, in an all-in-one unit. The BITE 2 and its accessories fit into a sturdy canvas case with a shoulder strap.

The instruments work by applying a test current across the battery string while on-line, then measuring the total current (ac ripple + test current) and the voltage drop of each cell/jar. It then calculates the impedance. They also measure dc voltage and interconnection (strap) resistance to help determine the overall condition of the entire battery string's electrical path from terminal plate to terminal plate.

The BITE 2 and BITE 2P receiver stores the readings in its internal memory. These measurements, along with other maintenance data such as ambient and pilot cell temperatures and ac ripple current, assist in determining the overall condition of battery systems. AVO International recommends that impedance measurements with the BITE 2 or BITE 2P be made part of a battery maintenance program with readings taken and recorded semiannually for flooded batteries and quarterly for VRLA.

Unlike load cycle testing that involves substantial downtime and repeated discharges, using the instruments require no battery discharge, nor do they stress the battery in any way compared to other techniques. With a test time of less than 20 seconds for each cell and intercell connector, one person can easily, quickly, and precisely measure internal cell impedance, dc terminal voltage and intercell connection resistance without taking the battery system off line.

Naturally, everything you need to perform these tests is included with the basic instruments. There is a full line of optional accessories to enhance the capabilities of the BITE 2 and BITE 2P. Both have the ability to download to a PC for data interpretation. Additionally, the BITE 2P has a built-in printer to review the active test but also to leave a hard copy record at the site.

Receiver

The battery-operated receiver incorporates the potential leads, clamp-on current sensor, and data storage capabilities. It stores more than 2000 sets of data (cell impedance, cell voltage and interconnecting strap resistance, date and time stamps) in up to 300 tests. It also allows for printing the active test for easy review and retest. Selective printing of any test and deleting oldest tests are now included features to maintain in memory the most critical tests.

At any time while performing a test, the operator can review the current test results by using arrow keys and scrolling back through the active test screen. The operator can also print the active test using the BITE 2P transmitter printer. If needed, the operator can retest any of the cells and straps in the current test. Stored data can also be downloaded via the RS-232 connector directly to a personal computer or the BITE 2P transmitter printer.

One additional feature of the receiver is that if you are called away while in the middle of the test, simply shut down the instrument and it will remember where you left off in the test.

The clamp-on current sensor is connected to the receiver during testing and clamped around a convenient intertier or intercell connection within the loop created by the transmitter's current source leads and the battery string. If the intercell or intertier connection consists of more cables than the diameter of the clamp-on current sensor can encompass, the receiver has a split-strap function.

There is an optional RopeCT™ available for large buss work. With the optional bar-code wand, additional information such as location ID, user ID, ambient and pilot cell temperatures can be recorded and stored. There is space on the printout to enter specific gravity readings.

Transmitter

The transmitter provides the capacitively coupled ac test current to avoid transients on the dc buss and applies the test current to the cells under test via the current source leads. Both the BITE 2 and BITE 2P transmitters have an LCD and built-in receiver charger, while the BITE 2P transmitter features a built-in printer.

Data, measured and stored in the receiver can be exported to a PC. It can also be printed to the BITE 2P transmitter printer where it can be reviewed. Figure 1 shows a sample printout of a full battery analysis report.

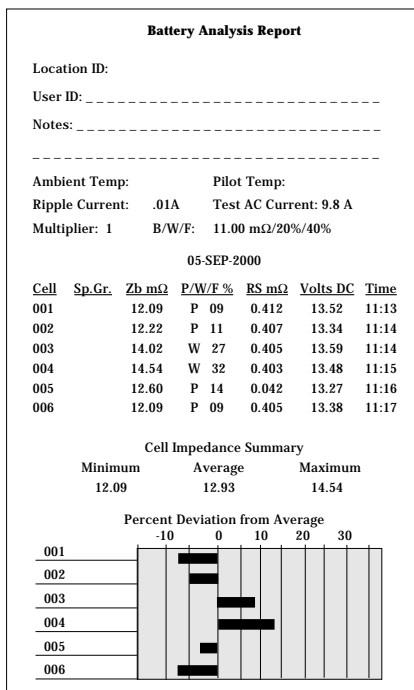

Figure 1. Sample battery analysis report

APPLICATIONS

A battery's internal impedance increases with decreasing capacity due to various conditions such as age, ambient temperature, discharge history, etc. See Figure 2. Both the BITE 2 and BITE 2P measure impedance values and dc voltage for lead-acid and nickel-cadmium cells up to 7000 Ah capacity.

Impedance finds electrical path problems due to plate sulphation, post-seal corrosion, dry-out, and poor intracell and intercell connections. This information lets the operator determine maintenance needs such as:

- Cell replacement criteria based on impedance trends.
- Jumpering out a cell or two.
- Clean and/or retorque intercell connectors.
- Shorten the maintenance interval, etc.

Typical installations that can be tested using the BITE 2 and BITE 2P include:

- Electrical power generation plants.
- Substations: utility, railroad, industrial.
- Telecommunications facilities: CO, Wireline, Wireless, MTSO.
- UPS systems.
- Railroad: Signals and Communications, substation
- Aircraft power supplies.
- Marine, military
- and many other applications.

FEATURES AND BENEFITS

- On-line testing requiring no downtime.
- Enhanced printing and memory functions.
- Calculates impedance automatically and stores results for on-site review.
- Requires no battery discharge.
- Receiver has an RS-232 connector for downloading stored data to a personal computer.
- Reduced test time: less than 30 seconds for each cell.
- Measures impedance and dc voltage values for all lead-acid and nickel-cadmium cells up to 7000 Ah.
- Stores more than 2000 sets of readings in up to 300 tests.

TEST PROCEDURE

The BITE 2 and BITE 2P work by applying a capacitively coupled ac test current across the battery string while on-line. The receiver and potential probe are placed at the cell terminals to measure the ac voltage drop and total ac current across each cell/jar. During each measurement, impedance is calculated following Ohm's Law, displayed on the LCD and stored. The instruments also measure, display and record dc voltage and interconnection (strap) resistance to help determine the overall condition of the entire battery string's electrical path from terminal plate to terminal plate.

The BITE 2 and BITE 2P receiver stores the readings in its internal memory. These measurements, along with other maintenance data such as ambient and pilot cell temperatures and ac ripple current, assist in determining the overall condition of battery systems. Figure 3 shows a typical test setup.

Interpretation of Readings

Data produced by the BITE 2 and BITE 2P can be interpreted in several modes: instantaneous, short-term and long-term time frames. An impedance distribution plot, as shown in Figure 4, assists in the analysis.

Instantaneous Interpretation

The operator can enter a baseline value from either the impedance measurements obtained at commissioning or from AVO International website. The percent changes from baseline for warning and fail levels are entered, but 20 percent and 40 percent are the default settings. The LCD on the receiver will display the status of the cell for a few seconds before proceeding to the next cell. The status of each cell/jar will be printed on the Battery Analysis Report.

Short-Term Interpretation

Impedance readings for individual cells can be used in the short term to compare with the average impedance readings for the entire battery string. Individual cell values with deviations of more than ± 15 percent for flooded lead-acid, ± 35 percent for VRLA, and 50 percent for NiCd cells from the battery string average typically indicate a problem with that cell. AVO recommends additional investigation of such cells including a verification of inter-cell connections and a single cell load-cycle test.

Long-Term Interpretation

Impedance readings for the entire battery can be used in the long term to determine replacement criteria. Battery cell impedance values should be recorded and compared to previous readings to determine the position of the cell on the curve of impedance versus cell life as shown in Figure 2. Based on experience, a variation of ± 20 percent from baseline for flooded lead-acid, ± 40 percent for VRLA and 50 percent for NiCd cells indicate significant change in the electrical path to warrant serious evaluation of the condition of the battery system. AVO maintains a database of impedance values by some manufacturers and battery size/type. For comparison purposes, this information is available upon request.

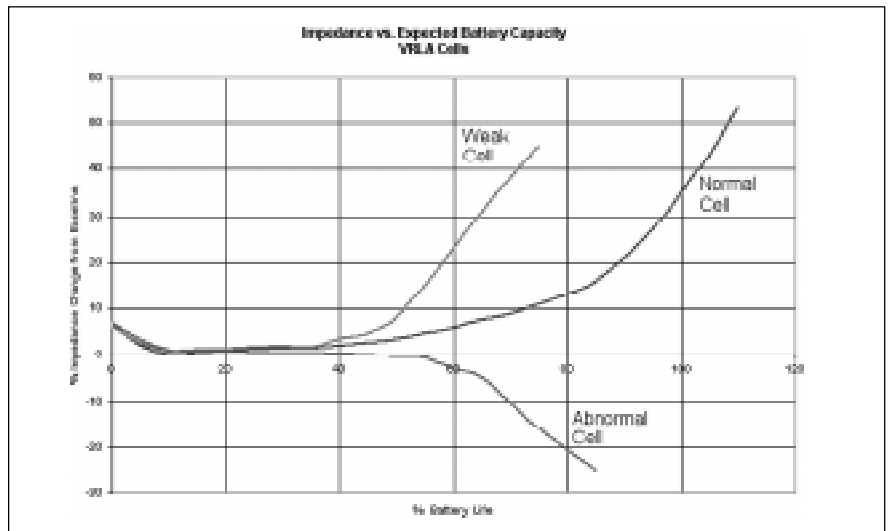

Figure 2. Impedance increases with battery age (and weakness).

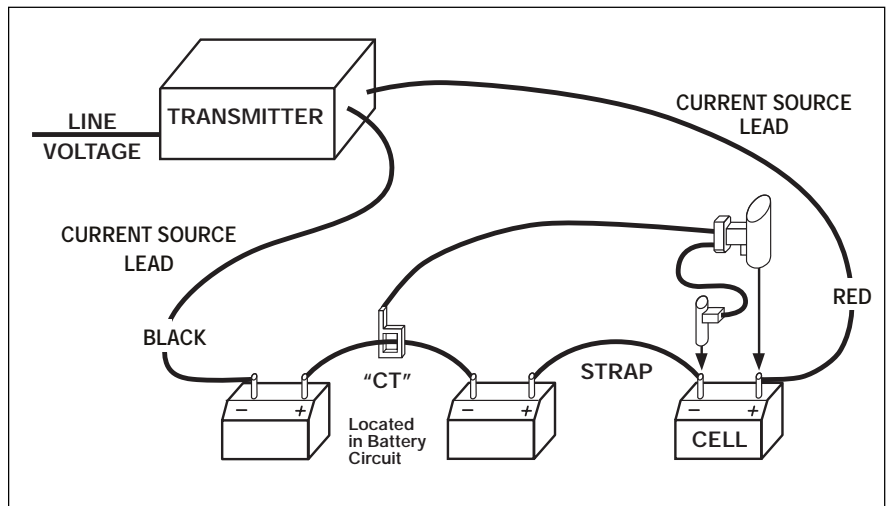

Figure 3. A typical test setup.

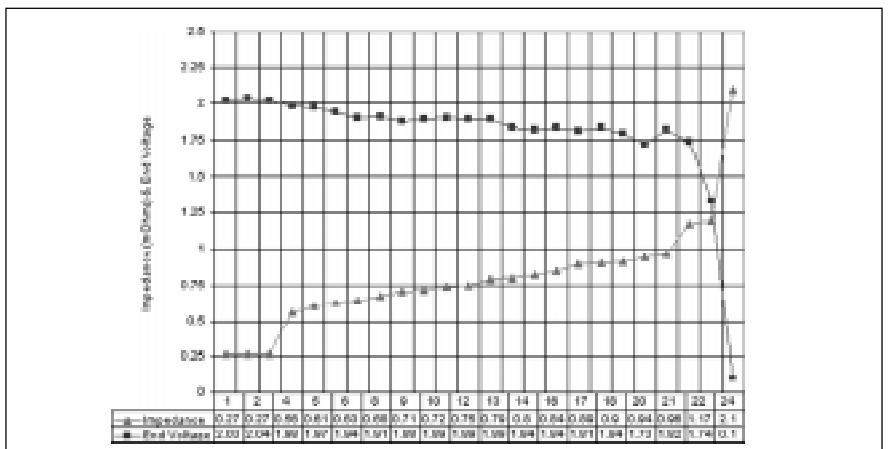

Figure 4. Ascending impedance compared to load test

SPECIFICATIONS

Application

The BITE 2 and BITE 2P test lead-acid and nickel-cadmium cells up to 7000 Ah.

Maximum Total Voltage at Current

Source Leads

275 V dc (larger battery systems can be sectioned to accommodate this specification)

Transmitter

Supply Voltage

100 to 130 V, 50/60 Hz, 200 VA max

210 to 250 V, 50/60 Hz, 200 VA max

Source Output Current

10 A nominal, 50/60 Hz operation

Maximum Battery String Test Voltage

275 V dc at source lead terminals (section the battery if >275 Vdc)

Display

Digital LCD meter, 0 to 15 A

BITE 2P Printer

Built-in thermal, with 4.25 in. (110 mm) printing width

Charger

Supply Voltage

100 to 130 V, 50/60 Hz, 14 VA

210 to 250 V, 50/60 Hz, 14 VA

Output

6.50 V dc @ 1.10 A dc charging (max)

9.60 V dc open circuit

Receiver

Accuracy

ac impedance $\pm(0.3\%$ of rdg +1 LSD)

dc voltage $\pm(0.5\%$ of rdg +1 LSD)

Precision

better than 0.5% one sigma

Voltage Range and Resolution

1 to 2.500 V dc, 1 mV resolution

2.5 to 25.00 V dc, 10 mV resolution

Impedance Range and Resolution

0 to 1.000 m Ω , 1 $\mu\Omega$ resolution

1 to 10.00 m Ω , 10 $\mu\Omega$ resolution

10 to 100.0 m Ω , 0.1m Ω resolution

Setting Time per Reading

3 seconds maximum

Supply

4.8 V dc, 800 mAh, quick charge

nickel-cadmium battery pack

Battery Pack Life, Full Charge

5 hours continuous

Maximum Cell/Jar Test Voltage

25 V dc between receiver and potential probe

Display

LCD, 2 x 16 characters

Temperature

Operating: 32 to 105° F (0 to 40° C)

Storage: -5 to 130° F (-20 to 55° C)

Humidity: 20 to 90% RH, noncondensing

Clamp Range

Standard CT

2.0 in. (50 mm) maximum opening

Optional Miniature CT

0.5 in. (12 mm) maximum opening

Optional RopeCT™

12 in. (300 mm) opening, approx.

Safety

Designed to meet IEC 1010-1

Dimensions

Transmitter

BITE 2: 6.5 H x 14 W x 10.6 D in. (16.5 H x 35.6 W x 27 D cm)

BITE 2P: 7.5 H x 18.5 W x 14.6 D in. (19 H x 47 W x 37 D cm)

Receiver (irregular shape)

7.25 H x 11.25 W x 2 D in.

(18 H x 29 W x 5 D cm)

Weight

Transmitter

BITE 2: 17 lb (7.7 kg)

BITE 2P: 18 lb (8.2 kg) alone
32 lb (14.5 kg) packed

Receiver

1.6 lb (0.7 kg)

ORDERING INFORMATION

Item (Qty)	Cat. No.	Item (Qty)	Cat. No.
BITE 2, 110/230 V ac, 50/60 Hz, CE-Marked	246002B	Optional Accessories	
BITE 2P, 110/230 V ac, 50/60 Hz, CE-Marked	246004	Current sensor 0.5 in. (12 mm)	
Included Accessories		opening with 2.5 ft (0.8 m) lead	246034
Transmitter		Current sensor, RopeCT™ 24 in. (60 cm) length	246050
for Cat No. 246002B	30044-600	Current sensor, RopeCT™ 36 in. (90 cm) length	246051
for Cat. No. 246004	30044-100	CT extension cable, 20 ft (6 m)	246033
Receiver	30620-3	Current source leads, 10 ft (3 m), fused	246147
Current Source Leads, 20 ft (6 m), fused	29386-2	Current source leads, 30 ft (9.1 m), fused	246347
Current sensor, 2 in. (50 mm)		Current source leads, 40 ft (12.2 m), fused	246447
opening with 5 ft (1.5 m) lead	33863	Bar-code wand with preprinted code sheet	246201
CT extension cable, 6 ft (1.8 m)	33864-1	Bar-code labeling software, Windows®	33506-2
Communication cable, 6 ft (1.8 m)	35340		
Thermal paper	26999		
AVOLink for Windows®	35303-2		
ac line cord, 8 ft (2.5 m)	17032		
Canvas carrying case for Cat. No. 246002B	218746		