



P. F. / PHASE ANGLE TRANSDUCER MODELS DPF/DPA

FEATURES

- Phase Angle (ϕ) or Power Factor ($\text{COS}\phi$).
- The bi-polar output for .5 PF or 60° lead and lag.
- Time between zero crossings measurement method.
- Measures non-sinusoidal and distorted waveforms.



POWER FACTOR (.5 LAG - 1 - .5 LEAD)



INPUT VOLTAGE LINE-TO-LINE	INPUT CURRENT (AMPS)	STANDARD OUTPUTS MODEL NUMBER DPF-			
		± 1mA	± 10Vdc	4-20mA	4-12-20mA
10 - 600	0.2 - 5	004A	004C	004E	004EM

ORDERING INFORMATION
Example: Power Factor 240Vac, 5 Amp input with ±10Vdc output. **DPF-004C**

PHASE ANGLE (-60° to 0 to +60°)

INPUT VOLTAGE LINE-TO-LINE	INPUT CURRENT (AMPS)	STANDARD OUTPUTS MODEL NUMBER DPA-			
		± 1mA	± 10Vdc	4-20mA	4-12-20mA
10 - 600	0.2 - 5	004A	004C	004E	004EM

All models require instrument power (85 - 230Vac/dc).

MODEL DPF/DPA SPECIFICATIONS

INPUT

VOLTAGE: 10 - 690V
CURRENT: 5A
FREQUENCY RANGE: 48 - 400Hz.
OVERLOAD (Continuous):
Voltage: 120% of F.S. input voltage
Current: 120% of F.S. input current
BURDEN:
Voltage: less than 1.0VA
Current: 0.1VA
ISOLATION: 4000Vac
SURGE: Withstands IEC 1010

OUTPUT

ACCURACY: ± 0.5% of span
OUTPUT RIPPLE: less than 0.5% p.p.
OUTPUT LOADING (OHMS):
± 1mA: 0 - 15K
± 10Vdc: 2.5K min.
4 - 20mA, 4-12-20mA: 0 - 750
RESPONSE TIME (90%): less than 100mS @ 60Hz
TEMPERATURE RANGE: -10° - +55°C
INSTRUMENT POWER: 85 - 230Vac/dc, 40 - 400 Hz, 4.0VA.

CASE DIMENSIONS

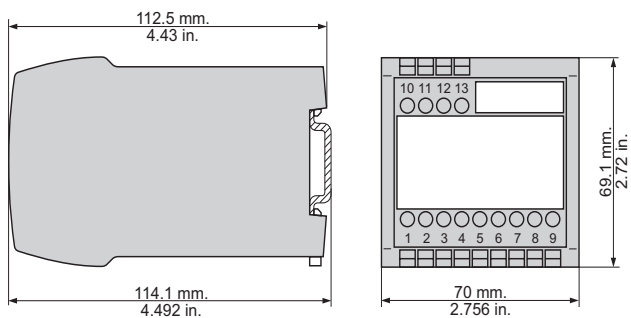

Mounted on 35 mm top-hat DIN rail.

CONNECTION DIAGRAMS

