



PHASE ANGLE TRANSDUCER

MODEL PF5

DESCRIPTION

The model PF5 provides a dc output which is linearly proportional to the phase angle difference between voltage and current of an ac power system. The polarity of the bipolar output indicates leading or lagging conditions.

Balanced load conditions are necessary in three-phase systems. Deviation from sine wave conditions leads to inaccuracies with all transducers since angle measurement is based on time difference between zero crossings.

FEATURES

- The bi-polar output of the model PF is directly proportional to the 0 - 60° leading or lagging power factor of the input signal. A leading PF is represented by a negative output signal. A lagging PF is represented by a positive output signal.

APPLICATIONS

- Provides an accurate means for calculating power factor, $PF = \cos \phi$.



SINGLE-PHASE, TWO-WIRE

INPUT VOLTAGE LINE-TO-LINE	INPUT CURRENT (AMPS)	STANDARD OUTPUTS MODEL PF5-			
		±1mA	±10Vdc	4-20mA*	4-12-20mA*
95 - 135	0.2 - 5	001A	001C	001E	001EM
	0.3 - 10	010A	010C	010E	010EM
	1 - 20	019A	019C	019E	019EM
200 - 300	0.2 - 5	002A	002C	002E	002EM
	0.3 - 10	011A	011C	011E	011EM
	1 - 20	020A	020C	020E	020EM
410 - 550	0.2 - 5	003A	003C	003E	003EM
	0.3 - 10	012A	012C	012E	012EM
	1 - 20	021A	021C	021E	021EM

ORDERING INFORMATION

Example: Three-phase, four-wire 240Vac, 10 Amp input with ±10Vdc output.
PF5-011C

HIGHER CURRENT RANGES AVAILABLE CONSULT FACTORY

THREE-PHASE, THREE-WIRE OR THREE-PHASE, FOUR-WIRE MODELS

INPUT VOLTAGE LINE-TO-LINE	INPUT CURRENT (AMPS)	STANDARD OUTPUTS MODEL PF5-			
		±1mA	±10Vdc	4-20mA*	4-12-20mA*
95 - 135	0.2 - 5	004A	004C	004E	004EM
	0.3 - 10	013A	013C	013E	013EM
	1 - 20	022A	022C	022E	022EM
200 - 300	0.2 - 5	005A	005C	005E	005EM
	0.3 - 10	014A	014C	014E	014EM
	1 - 20	023A	023C	023E	023EM
410 - 550	0.2 - 5	006A	006C	006E	006EM
	0.3 - 10	015A	015C	015E	015EM
	1 - 20	024A	024C	024E	024EM

*4 - 20mA, 4 - 12 - 20mA models require 85 - 135Vac instrument power.

All other models are self-powered from monitored line. 4 - 20mA models for use **only on lagging Power Factor.**

Add suffix "- 22" for 220Vac

MODEL PF5 SPECIFICATIONS

INPUT

VOLTAGE: See tables
CURRENT: See tables
FREQUENCY RANGE: 50 - 60 Hz.

OVERLOAD (Continuous):

Voltage: 135V range: 175V
300V range: 350V
550V range: 600V

Current: 5A range: 10A
10A range: 20A
20A range: 30A

BURDEN:

Voltage: 2.0VA
Current: 0.4VA

DIELECTRIC TEST (INPUT/OUTPUT/CASE): 1500Vac

SURGE: Withstands IEEE SWC test

OUTPUT

ACCURACY: ±0.5% of span

(Includes combined effects of voltage, current and frequency.)

OUTPUT LOADING (ohms):

±1mA: 0 - 10K

±10Vdc: 2K minimum

4 - 20mA, 4 - 12 - 20mA: 0 - 500

RESPONSE TIME (90%): 400 milliseconds

FIELD ADJUSTABLE CAL.: ±10%

TEMPERATURE EFFECT (-20° to +60°C): ±0.5% F.S.

INSTRUMENT POWER: 85 - 135Vac, 50 - 400 Hz, 3.5VA.

OHIO SEMITRONICS, INC.

SINGLE-PHASE CONNECTIONS

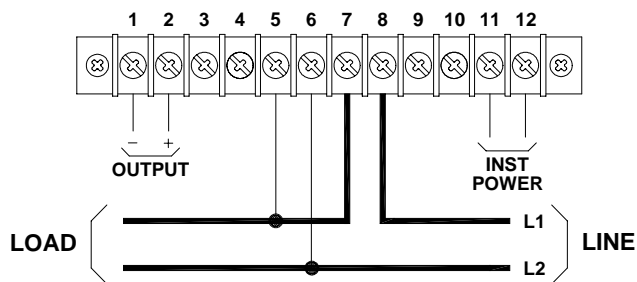

DIRECT CONNECTION

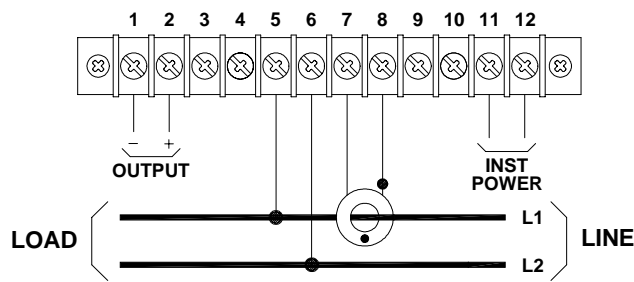

USING CURRENT TRANSFORMERS

THREE-PHASE, THREE-WIRE AND THREE-PHASE, FOUR-WIRE CONNECTIONS

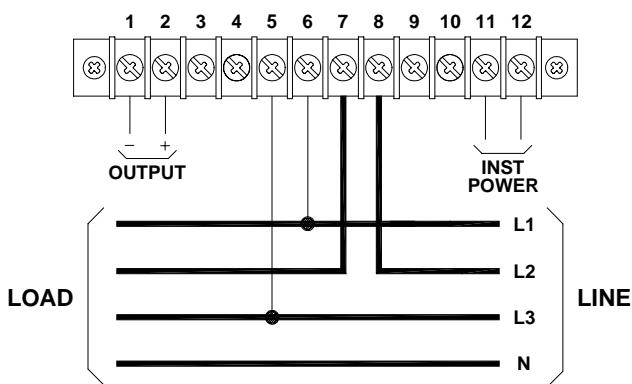

DIRECT CONNECTION

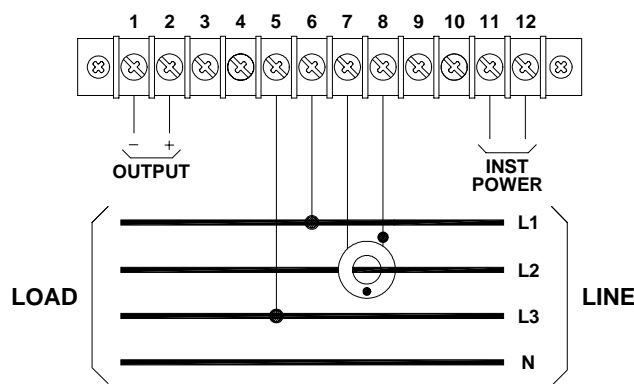

USING CURRENT TRANSFORMERS

INSTALLATION NOTE: Proper installation of the model PF phase angle transducer is critical. *The connection diagrams shown above must be followed precisely.* If the application requires the use of current transformers, insure that polarity is correct. Any deviation from the connections shown will result in a locked full-scale output signal.

FREQUENCY & POWER FACTOR

AC

CASE DIMENSIONS

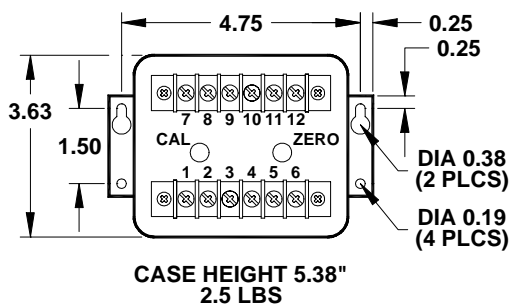

CASE HEIGHT 5.38"
2.5 LBS

All dimensions in inches.