

13540 N FLORIDA AVE.
SUITE 105
TAMPA FL 33613



OMNI CONTROLS, INC.

813-960-3445
FAX 813-960-4779
www.omnicontrols.com



**ACTION
INSTRUMENTS**

*Protecting the
Integrity of
Industrial Process
Signals*

ACTION PAK® AP4001 & AP4151 MODEL



Benefits

- Direct RTD Input
- Integral Lead-Length Compensation
- Temperature Control/ Monitoring Applications
- Easy Plug-in Installation/ Low Mean-Time-to-Repair
- AC Line Powered (DC Optional)
- Fixed-Range Input & Output
- Three Year Warranty



RTD Input, Signal Conditioners

Provides a DC Output in Proportion to an RTD Input

DESCRIPTION

The two models of RTD input signal conditioners provide the following input to output relationship

AP4001 Linear to resistance

AP4151 Linear to temperature

APPLICATIONS

Action Pak models AP4001 and AP4151 are useful in any application requiring a DC output from an RTD input. Typical applications include energy management and data acquisition of process temperatures. The output of a 4000 series RTD signal conditioner can drive a digital meter for direct display, or interface with a computer for monitoring and control.

OPERATION

The constant current RTD excitation uses the third lead of the RTD to sense and compensate for the RTD lead resistance, resulting in an accurate RTD temperature measurement. The RTD voltage is then amplified and buffered by an output stage which allows adjustment of zero and span. The AP4151 uses feedback linearization, changing the RTD excitation current to correct the temperature/resistance non-linearity. In units having a current output (e.g. 4-20mA), the output is a current source controlled by the output buffer. With voltage output units (e.g. 0-10V), the output is taken directly from the buffer. An internal transformer isolates the process from line power.

OPTIONS

- CS** Canadian Standards Association Certification.
- U** Urethane coating of internal circuitry for protection from corrosive atmospheres

An Invensys Company

SPECIFICATIONS

RTD Excitation Current	1 to 10mA, depending on RTD type
Leadwire Resistance	
(Maximum Ω/Lead)	100 Ω RTD: 40 120 Ω RTD: 40 500 Ω RTD: 100 10 Ω RTD: 30
Leadwire Effect	Less than 1% of span error
AP4001 Linearity (Best Straight Line and Linear Input)	$\pm 0.1\%$ of span typical (referred to resistance input)
AP4151 Accuracy	$\pm 0.1\%$ of span typical (referred to temperature input)
Output Impedance	Voltage Output: Less than 10 Ω Current Output: >100K Ω
Output Drive	Voltage Output: 10mA, max (1K Ω , min.) Current Output: 15V compliance @ 20mA (750 Ω , max)
Stability	$\pm 0.05\%$ of span/ $^{\circ}$ C typical

Response Time	100 mSec typical
Output Ripple	0.2% of max. span or 5mV rms, whichever is greater 24VDC power: 0.5% of max. span or 10mVrms, whichever is greater
Common Mode Rejection	60 Hz: > 120dB DC: > 100dB
Common Mode Voltage	500V DC or peak AC, max.
Temperature Range	Operating: 0 to 60 $^{\circ}$ C (32 to 140 $^{\circ}$ F) Storage: -20 to 85 $^{\circ}$ C (-4 to 185 $^{\circ}$ F)
Power	Consumption: 3W typical, 5W max Standard: 120VAC ($\pm 10\%$, 50 to 400Hz) Available: 240VAC, ($\pm 10\%$, 50 to 400Hz) Optional: 24VDC, ± 8 V, inverter-isolated, (Mark II Case)
Weight	AP4001 0.54lbs AP4151 0.52lbs

CALIBRATION

Top accessed screwdriver adjustments provide typical $\pm 10\%$ zero and span adjustability. Calibration is referred to input in that adjustments are to correct for input/sensor variations.

For models AP4001 and AP4151, zero is adjusted for the specified minimum output with the RTD input at the desired minimum temperature. Span is adjusted for the specified maximum output, with the RTD input at the desired maximum temperature. Repeat adjustments for best accuracy.

INPUT/OUTPUT RANGES

Tables 1 and 2 lists all the available standard inputs and outputs. For better resolution, non-standard ranges are also available within the limits shown in Table 3 and 4.

PRODUCT ASSISTANCE:

For additional information on calibration, operation and installation please contact Our Technical Services Group. Call toll-free:

800-783-6664

Table 1: AP4001/AP4151 Standard Inputs*

0 to 200 $^{\circ}$ F	0 to 100 $^{\circ}$ C
0 to 300 $^{\circ}$ F	0 to 150 $^{\circ}$ C
0 to 400 $^{\circ}$ F	0 to 200 $^{\circ}$ C
0 to 500 $^{\circ}$ F	0 to 250 $^{\circ}$ C
0 to 1000 $^{\circ}$ F	0 to 500 $^{\circ}$ C

*100 Ω Pt RTD, 0.00385 Ω/Ω° C [DIN Standard]

Note: Consult factory for ranges not listed or other input/output range availability.

Table 2: AP4001/AP4151 Standard Outputs

0-1V	0-5V	1-5V
0-10V	4-20mA	10-50mA

Table 3: AP4001/AP4151 Output Limits

Minimum Span		Maximum Span	
Voltage	Current	Voltage	Current
100mV	1mA	10V	50mA

Table 4: AP4001/AP4151 Input Limits

RTD	Useable Range	Minimum Span
100 Ω Pt	-328 to 1600 $^{\circ}$ F (-200 to 870 $^{\circ}$ C)	50 $^{\circ}$ F (30 $^{\circ}$ C)
200 Ω Pt	-328 to 1600 $^{\circ}$ F (-200 to 870 $^{\circ}$ C)	40 $^{\circ}$ F (20 $^{\circ}$ C)
500 Ω Pt	-328 to 1600 $^{\circ}$ F (-200 to 870 $^{\circ}$ C)	20 $^{\circ}$ F (10 $^{\circ}$ C)
100 Ω Ni	-148 to 590 $^{\circ}$ F (-100 to 310 $^{\circ}$ C)	40 $^{\circ}$ F (20 $^{\circ}$ C)
120 Ω Ni	-112 to 608 $^{\circ}$ F (-80 to 320 $^{\circ}$ C)	40 $^{\circ}$ F (20 $^{\circ}$ C)
10 Ω Cu	-328 to 500 $^{\circ}$ F (-200 to 260 $^{\circ}$ C)	180 $^{\circ}$ F (100 $^{\circ}$ C)

DIMENSIONS

Dimensions are in millimeters (Inches)

Mark I (Standard)

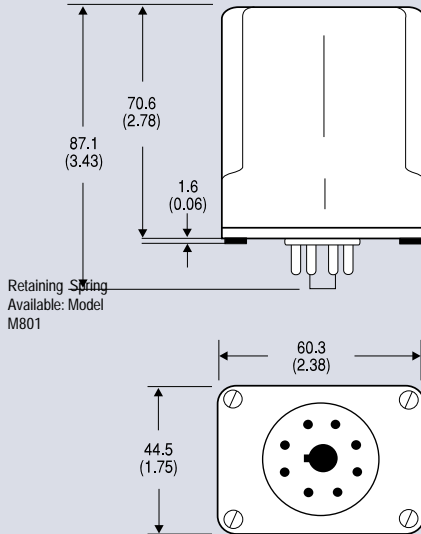

M008(Track/Surface)

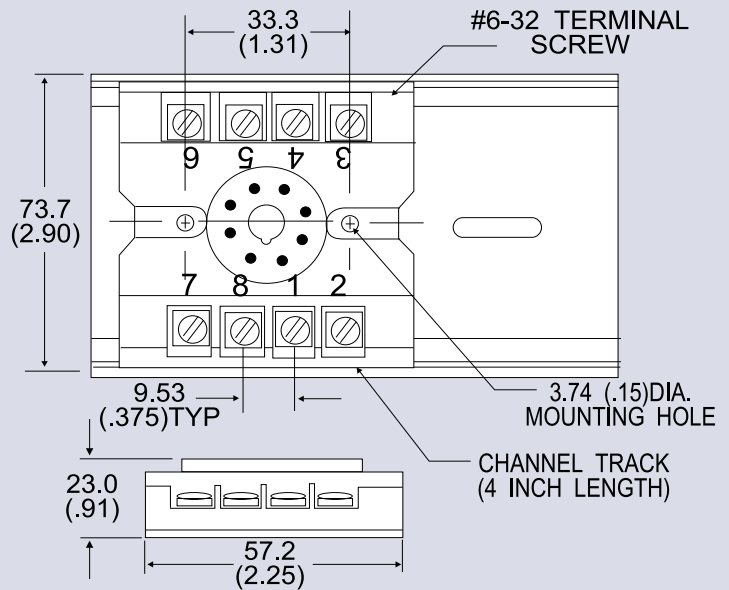

Mark II (24VDC)

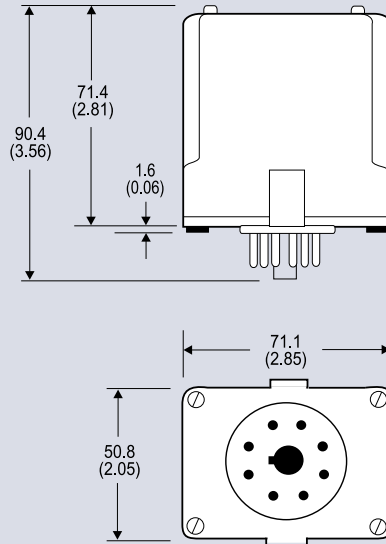

MD08(DIN/Surface)

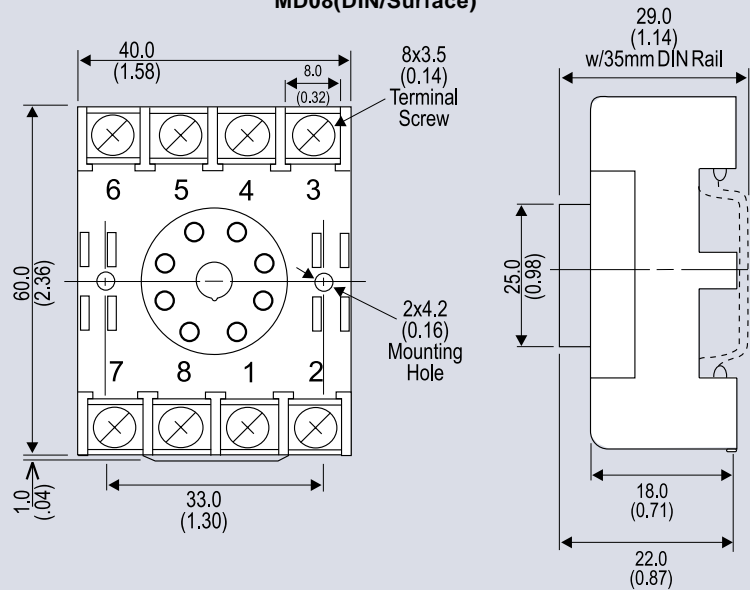

MODELS & ACCESSORIES

Mounting

All Action Paks feature plug-in installation. Models AP4001 and AP4151 use 8-pin bases and either molded socket M008 or DIN socket MD08.

Ordering Information

Specify:

1. Model(s): **AP4001, AP4151**
 2. Input Range (see Tables 1, 4)
 3. Output Range (see Tables 2, 3)
 4. Options: CS, U (see text)
 5. Line Power (see specifications)
- (All power supplies are transformer-isolated from the internal circuitry.)

Pin Connections

AP4001 & 4151

- 1 AC Power (Hot)
 - 2 Shield (Gnd.)
 - 3 AC Power (Neu.)
 - 4 RTD Return
 - 5 RTD Input (-)
 - 6 RTD Input (+)
 - 7 Output (+)
 - 8 Output (-)
- DC power 1(+) 3(-)

