

ACTIONI/Q[®] Q408

MODEL



Benefits

- Protects Equipment and Prevents Ground Loops with 1800V Isolation
- Easy Field Configurable Input Ranges: 10mV to 100V, 1mA to 100mA
- Five Field Configurable Output Ranges: 0-5V, 0-10V, 0-1mA, 0-20mA, 4-20mA
- Touch CAL™ Technology for Easy, Non-Interactive Zero and Span Adjustments
- High Density DIN Rail Mounting
- SnapLoc™, Plug-In Terminals for Low MTTR
- Flexible Power Supply Accepts 9 to 30VDC
- ASIC Technology for High Reliability
- Lifetime Warranty



*Protecting the
Integrity of
Industrial
Process Signals*

DC Input, Field Configurable Isolator

Provides One or Two, Fully Isolated DC Output Signals in Proportion to One or Two DC Inputs

DESCRIPTION

The ActionI/Q model Q408 is an DC powered, DIN rail mount, DC input signal conditioner, with 1800V isolation between input, output and power. The field configurable input and output feature offers flexible, wide ranging capability for DC current and voltage signals.

Advanced technology has added two significant improvements to this new DC to DC signal isolator.

First, advances in surface mount design and switching power supply technology allow multi-channel density. The Q408 is available as a single channel signal conditioner (1 input/ 1 output) or a multi channel signal conditioner (2 inputs/ 2 outputs). All models maintain the high 1800V isolation level from channel to channel, as well as input to output to power.

Second, low-cost microprocessor technology has enabled replacement of zero and span adjustment potentiometers with push-button, "TouchCAL™" technology. In essence, the thermal drift and mechanical variability of the potentiometers have been removed and replaced with a digitally stable circuit. Additionally, the inherent zero and span interactivity of potentiometer based analog amplifier circuitry is removed, providing 100% non-interactive adjustment.

The field configurable input of the Q408 can be set via DIP switches for any one of 12 voltage ranges from 10mV to 100V or 6 current ranges from 1mA to 100mA (see Table 1). The field configurable output is linear to the input and can be set for either 0-5V, 0-10V, 0-1mA or 4-20mA.

TouchCAL technology enables precise calibration and provides more than 90% offset of the zero value and adjustment down to 10% of the full scale input span for most of the 18 switch selectable input ranges. For example, the dipswitch configured 0-20mA input range



could be calibrated via push button for 0-8mA (i.e. 60% span reduction) or offset to a range of 12-20mA (i.e. 60% offset and 60% span reduction). If the output was configured for 0-10V, then 12-20mA input would correspond to the 0-10V full scale output. Thus, input ranges such as 18-20mA or 0-2mA are possible using the 0-20mA range.

Advanced digital technology combined with Action’s exclusive ASIC technology allows the Q408 to be field configured for virtually any DC input to DC output within the limits specified. Calibration utilizes “TouchCAL” technology where the user simply configures the input for the current or voltage range via switches, then applies the minimum and maximum input signals, touching a recessed button to store range values.

The Q408 will accept power between 9 and 30VDC; typically a 12 or 24VDC source is used. sible using the 0-20mA range.

APPLICATION

The ActionI/Q Q408 field configurable isolator is useful in eliminating ground loops, converting signal levels, and providing signal drive. The field configurable, wide ranging capabilities ensure maximum flexibility for most DC to DC applications, minimizing spare parts requirements.

TOUCHCAL™ TECHNOLOGY

The Q408 utilizes Action Instruments’ TouchCAL technology which greatly simplifies calibration. Once the unit is configured via DIP switches for voltage or current, the push-button is used to precisely calibrate the minimum and maximum levels.

To set the input level within the dip switch configured range, the user simply applies the high input signal (voltage or current) and pushes the CAL button. The low input signal is then applied and pushing the CAL button again stores the low input signal.

The high and low input levels are stored in nonvolatile memory and correspond to the high and low output levels. These output levels are precisely adjusted using the input signal.

DIAGNOSTIC LEDs

The Q408 has three diagnostic LEDs. One green LED, labeled RUN, is used for diagnostics to indicate that power is on, and it will flash quickly if the input signal is above the configured range or slowly if the input signal is below range. The RUN LED is continuously on when the unit is functioning within the configured range.

The yellow INLED is on while calibrating the input and the red OUT LED is on while calibrating the output.

CONFIGURATION

A major advantage of the Q408 is its wide ranging capabilities and ease of configuration. The Q408 can be configured for input ranges from 10mV to 100V or 1 mA to 100mA, with >90% input offset or it will adjust down to <10% of full scale input span (except on 20mV/2mA range where maximum offset or gain adjustment is 50%).

Unless a specific custom calibration is specified, the factory presets the Model Q408 as follows:

Input Range: 20mA (Current on)
 Input Configuration: Unipolar
 Calibrated Input: 4-20mA
 Operation: Direct (Reverse off)
 Calibrated Output: 4-20mA

Regarding other I/O ranges, refer to Table 1 for input range (SW1) switch settings, Table 2 for input function settings and Table 3 for output ranges (SW2). Refer to Table 4 to configure the multi-channel modules. For quick and easy calibration mode reference, see the step-by-step flow chart in Figure 2.

1. With power off, snap off the face plate by lifting the right edge, away from the heat sink. Then, slide the heat sink forward and off the module.

Table 1: Input Range Selector- Switch Settings for single channel modules.

Input Ranges		SW1			
Voltage	Current	1	2	3	4
20mV	2mA			■	■
50mV	5mA		■		
100mV	10mA		■		■
200mV	20mA		■	■	
500mV	50mA		■	■	■
1V	100mA	■			
2V		■			■
5V				■	■
10V		■	■		
25V		■	■	■	
50V		■	■	■	■
100V		■	■	■	■

Table 2: Input Range and Function Settings for single channel module.

TYPE	SW1			
	5	6	7	8
UNIPOLAR	■			
BIPOLAR		■		
REVERSE			■	
DIRECT				■
CURRENT				■
VOLTAGE			■	

KEY: ■ = closed

Table 3: Output Range Selector-Switch Settings for single channel module.

Output Ranges	SW2							
Q408-0000	1	2	3	4	5	6	7	8
0 to 5V	■	■	■	■				
0 to 10V	■	■	■	■				
0 to 1mA		■						
4 to 20mA						■	■	■
0 to 20mA	■	■				■	■	■

Table 4: Output Range Selector-Switch Settings for dual channel module. Check input settings; Note they should be set for voltage or current, not both voltage and current.

Ranges	SW1 or SW2*									
Input	1	2	3	4	5	6	7	8	9	10
20mV/2mA			■	■						
50mV/5mA		■								
100mV/10mA		■		■						
200mV/20mA		■	■							
500mV/50mA		■	■	■						
1V/100mA	■									
2V	■			■						
5V	■		■	■						
10V	■	■								
25V	■	■	■							
50V	■	■	■	■						
100V	■	■	■	■						
Unipolar					■					
Voltage						■				
Current							■			
Output	1	2	3	4	5	6	7	8	9	10
0 to 5V									■	■
0 to 10V									■	
0 to 1mAV										■
4 to 20mAV										■

*Applies to dual channel model

SPECIFICATIONS

Input	Voltage Input	INPUT (yellow): on while calibrating the input level
	Range Limits: 10mV to 100V (see Table 1) Impedance: $\geq 100K\Omega$ Overvoltage: 200V continuous	OUTPUT (red): on while calibrating the output level
Output	Current Input	> 2mA / > 20mV input spans: $\pm 0.1\%$ of full-scale input typical, $\pm 0.2\%$ maximum
	Range Limits: 1mA to 100mA Impedance: 20Ω typical Overcurrent: 170mA, protected by self-resetting fuse Overvoltage: 60V	< 2mA / < 20mV input spans: $\pm 0.35\%$ of fullscale input typical, $\pm 0.5\%$ maximum; including linearity, repeatability and hysteresis @23C.
LED Indication	Push-button Adjustment (inputs > 10mV)	< 50% offset or span adjust: < 0.1% off full scale span or 25mV RMS, whichever is greater
	Effective zero offset: $\geq 90\%$ Effective span turn down: $\geq 90\%$ except for 20mV/2mA range where 50% is maximum zero offset and span turn down	> 50% offset or span adjust: < 0.2% of full scale span or 50mV RMS, whichever is greater.
Output Accuracy	Voltage Output	200mSec, typical
	Output: 0-5V, 0-10V Source Impedance: < 10Ω Drive: 10mA max.	$\pm 0.025\%$ of full scale /C, maximum for fullscale and zero
Output Ripple	Current Output	Excitation Voltage) (optional) 24VDC, 20mA maximum
	Output: 4-20mA, 0-1mA (and 0-20mA on single output channel versions only) Source Impedance: > $100K\Omega$ Compliance: 0-1mA: 7.5V max. ($7.5K\Omega$) 4-20mA: 12V max. (600Ω)* 0-20mA: 12V max. (600Ω) * 10V max. (500Ω) on dual output versions	Common Mode Rejection 120dB at DC, > 90dB at 60Hz
Response Time	Compliance:	Isolation $\geq 1800VDC$ or peak AC between input, output, power and channel to channel
	0-1mA: 7.5V max. ($7.5K\Omega$) 4-20mA: 12V max. (600Ω)* 0-20mA: 12V max. (600Ω) * 10V max. (500Ω) on dual output versions	ESD Susceptibility Capable of meeting IEC 801-2 level 3(8kV)
Stability	Compliance:	Humidity Operating: 15 to 95% RH(@45°C) Soak: 90% RH for 24 hours(@60°C)
	0-1mA: 7.5V max. ($7.5K\Omega$) 4-20mA: 12V max. (600Ω)* 0-20mA: 12V max. (600Ω) * 10V max. (500Ω) on dual output versions	Temperature Operating: 0 to 55°C (32 to 131°F) Storage: -25 to 70°C (-13 to 158°F)
Excitation Voltage)	Compliance:	Power 2.5W max; 100 to 240VAC, $\pm 10\%$, 50 to 400Hz
	0-1mA: 7.5V max. ($7.5K\Omega$) 4-20mA: 12V max. (600Ω)* 0-20mA: 12V max. (600Ω) * 10V max. (500Ω) on dual output versions	Wire Terminal Socketed screw terminals for 12-22 AWG
Common Mode	Compliance:	Agency Approvals CSA certified per standard C22,2 (File No LR 42272). UL recognized per standard UL508 (File No. E99775). CE Mark pending.
	0-1mA: 7.5V max. ($7.5K\Omega$) 4-20mA: 12V max. (600Ω)* 0-20mA: 12V max. (600Ω) * 10V max. (500Ω) on dual output versions	

2. The single channel module has two eight position switch blocks, one for input and one for output.

3. The dual output modules have a patio board behind the heat sink. Gently lift this board away from the main board, rocking it back while lifting. This module has two ten position switch blocks, one for each channel.

WARNING: Do not attempt to change any DIP SWITCH settings while power is applied. Severe damage will result!

4. For single channel modules, choose the desired input, function and output range from Table 1, 2, and 3. For multi-channel modules, use Table 4. Set the dip switches for the desired I/O.

CALIBRATION

For best results, calibration should be performed in the operating installation, allowing at least one hour for thermal stability of the system. If pre-calibration on a test bench is preferred, then an output load equal to the input impedance of the device(s) connected to the Q408 output is recommended, along with a 1 hour warm up period.

1. For best results install the module on to a piece of DIN rail or the I/Q Rail mounting accessories if desired. See the I/Q Rail Data sheet for details.

Note: An I/Q Rail is an optional accessory to deliver power to the modules. A two, four or eight position rail is available. See ordering information.

2. Connect the input to a calibrated DC source and the output to a voltage or current meter. Apply power and allow the system to reach thermal equilibrium (approx. 1 hour).

3. Adjust the input signal to the desired maximum and observe that the green LED is on or flashing. Push the CAL button and hold it down for more than 5 seconds, until the yellow and Green LEDs are flashing.

Note: To quit the calibration mode and reset the unit, push the CAL button and hold for more than 5 seconds, again. Or, wait for more than two minutes and the unit will time-out and automatically reset to the previously stored calibration.

4. When the yellow and green LEDs stop flashing, the yellow and red LEDs should be on. Push the CAL button momentarily, the yellow and green LEDs should now be on.

5. Apply the exact maximum input signal level desired, if not already applied, then push the CAL button to store. The yellow LED should now be on.

Note: For reverse operating mode (SW1-6, closed), input the minimum signal in step 5 of calibration.

6. Apply the exact minimum input signal level desired, then push the CAL button to store. The green and red LED should now be on.

Note: For reverse operating mode (SW1-6, closed), input the maximum signal in step 6 of calibration.

7. Adjust the input signal up, until the output is precisely at the desired maximum level (e.g. 20.00mA), then push the CAL button to store. The red LED should be on.

8. Adjust the input signal level down, until the output is precisely at the desired minimum level (e.g. 4.00mA), then push the CAL button to store. The yellow, green and red LEDs should now be on.

9. To finish calibration, push the CAL button one final time. The green LED should be on if the input is within the calibrated range.

- (Y) Yellow LED (Y) Off
- (G) Green LED (Y) On
- (R) Red LED (Y) Flash



Note:
 1. Green LED slow flash(2Hz): input underflow
 Green LED fast flash(4Hz): input overflow
 2. Automatic quit to normal operation if no button push within 5 minutes.
 3. To skip a step, hold button for >2.5 sec., but <5.0 sec.
 4. To abort the setup, hold button for >5 sec.

Figure 1: Q408 Calibration Flow Chart.

DIMENSIONS

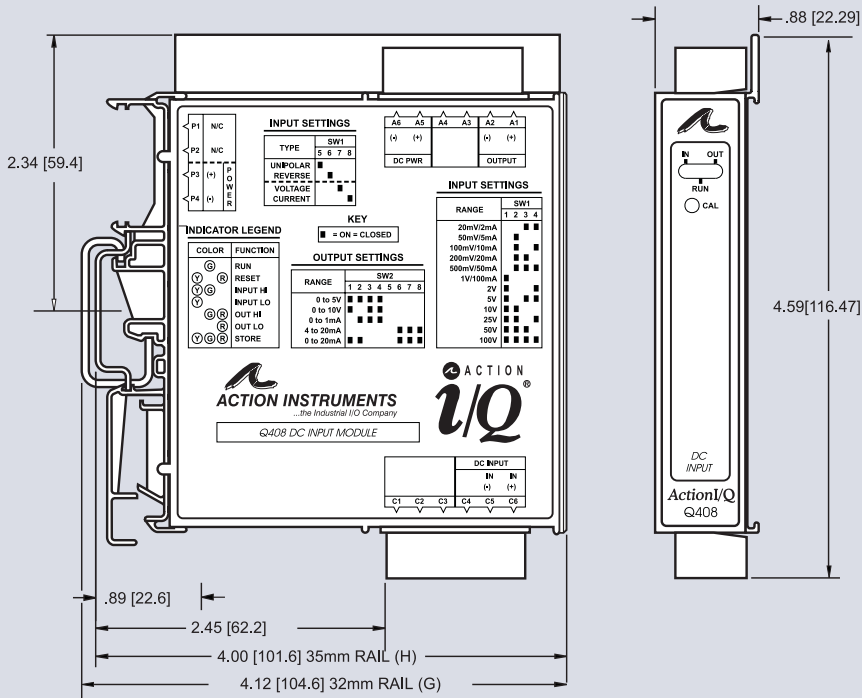

ASSISTANCE:

For additional information on calibration, operation and installation please contact our Technical Services Group. Call toll free:

800-783-6664

MODELS & ACCESSORIES

Accessories

All Action/IQ modules mount on standard TS32 (model MD02) or TS35 (model MD03) DIN rail. In addition the following accessories are available:

- MD02** TS32 DIN rail
- MD03** TS35 x 7.5 DIN rail
- IQRL-D002** 2 Position I/QRail & DIN rail
- IQRL-D004** 4 Position I/QRail & DIN rail
- IQRL-D008** 8 Position I/QRail & DIN rail
- G905** 24VDC Power Supply (0.5Amp)
- H910** 24VDC Power Supply (1Amp)
- H915** 24VDC Power Supply (2.1Amp)

Ordering Information

Specify:

1. Model: **Q408-0000**; one input, one output DC Isolator or **Q408-0004**; two input, two output DC Isolator
2. Specify optional I/QRail, type and quantity.
3. Optional Factory Custom Calibration, specify **C620** - with desired input and output ranges.
4. Accessories: (see Accessories)

Terminal Connections

- A1: Output (+), Channel 1
- A2: Output (-), Channel 1
- A3: Output (+), Channel 2
- A4: Output (-), Channel 2
- A5: DC Power (+)
- A6: DC Power (-)
- C1: Input (-), Channel 2
- C2: Input (+), Channel 2
- C3: Not Internally Connected
- C4: Not Internally Connected
- C5: Input (-), Channel 1
- C6: Input (+), Channel 1
- P1: Not Used
- P2: Not Used
- P3: DC Power (+)
- P4: DC Power (-)