

# TRANSPAK™ T797 & T798

**MODEL**



*Protecting the  
Integrity of  
Industrial  
Process Signals*

## Temperature Input, Smart, Isolating Two-wire Transmitter

Provides an Isolated, Linearized  
Current Loop in Proportion to an  
RTD or Thermocouple Input

### Benefits

- Highway Addressable Remote Transducer (HART) Compatible Protocol (T798) or Field Configurable with Optional Alpha-numeric Display (T797 & T798)
- Intrinsically Safe Operation (FM, CSA, CENELEC pending) or with Display and EP Enclosure
- Programmable for 11 Thermocouple Types, 6 RTD Types, mV or Ohm Inputs
- Eliminates Ground Loops with 500VAC Input to Output Isolation
- Minimal Calibration Requirements with Long Term Stability Better Than 0.025%/Year
- Three Year Warranty

### DESCRIPTION

The model T798 is a smart, Highway Addressable Remote Transducer (HART) based, temperature transmitter that can be factory or field configured using an optional 1 or 2 line alpha-numeric display, optional PC based modem and software. Alternatively an HC275 Hand Held Communicator loaded with the Action T798 Device Description from the Hart Foundation Library can be used.

The model T797 is a programmable temperature transmitter that can be factory or field configured using the same optional 1 or 2 line alphanumeric display as the T798.

Both the T798 and T797 accept a wide variety of thermocouple (B, C, E, J, K, L, N, R, S, T, U & special) and 2, 3, or 4 wire Platinum RTDs (DIN  $\mu = 0.00385$ , SAMA  $\mu = 0.003923$  and special) as well as millivolt (mV) and resistance inputs. They provide an isolated 4-20mA output loop that is proportional and linear to the desired temperature input range when configured appropriately. The factory can configure custom curves and accommodate other input types including 10 Ohm Copper and 120 Ohm Nickel RTDs.

### PROGRAMMING VIA HART

Utilizing HART protocol, the T798 can be accessed and programmed for dual two-wire RTD or dual thermocouple measurement, transmitting or displaying differential or average temperatures. For RTDs secure or independent dual RTD measurements can be made. Other functions can be set using Hart, such as input dampening, burnout detection, fail-safe report (sensor or transmitter failure produces over or under output range condition), loop test (manual control of output current), line frequency filtering, smart smoothing (filters small changes but reacts quickly to large changes),



internal temperature, cold junction temperature and display or transmitter identification (e.g. display label, tag ID, descriptor, message, sensor serial number, configuration date, etc.).

### CONFIGURING VIA DISPLAY

For quick and easy configuration the optional one line and two line alphanumeric displays (model T79D-1 and T79D-2) are extremely useful for set up and trimming the 4-20mA output or display reading to correct for sensor errors. These displays provide a 4 digit reading of the temperature (e.g. 2345, 234.5, 23.45) and will alert the user in the case of sensor failure or burnout for both RTDs and thermocouples by flashing 'fail' and 'safe' sequentially.

Another advantage of the display is that it will indicate the measured temperature even if the signal is in an out of range condition for the output. For example the factory default setting is J-type thermocouple 40 to 200°F input to 4-20mA output. If the input measures 300°F, which is out of the configured 40 to 200°F range, then the output will be forced to its maximum level 23mA, however the display will accurately read 300.0°F.

The displays can be set for degrees F, C, R and K. The two-line display indicates the units and clearly displays the sensor types during configuration. The one line display does not show the units (i.e. F, C, R or K) unless it is physically labeled and the input types during configuration are coded (see user manual for the 4 digit codes).

### SAFE INSTALLATIONS

Both the T797 and T798 are available in intrinsically safe and non-intrinsically safe configurations. The non-intrinsically safe versions are typically used with the alphanumeric displays and the windowed explosion proof (EP) enclosure for hazardous environments, or with the DIN rail mounting option instead of the EP enclosure for benign panel mount applications.

The intrinsically safe versions are designed to meet the Entity Parameters necessary for FM, CSA and CENELEC approval (pending) for Class I Division I, Groups A, B, C and D; and Class II, Division I, Groups E, F, & G and Class III Division I, when installed in accordance with Drawing #732-0220-00 for T797 and #732-0221-00 for T798. See the specifications for Nonincendive approval ratings and for the approval ratings of the EP enclosures.

Action Instrument's T79X series of smart programmable transmitters offers the features, functions and options required for easy operation in the most demanding applications. Accuracy, repeatability and long term stability performance are essentially the best that technology has to offer. See the Specification section of this data sheet for more details.

### APPLICATION

The T797 and T798 are ideal for any application requiring a 4-20mA two-wire transmitter loop output in proportion to a tem-

perature, mV or resistance input. In applications where the advantages of communications with a Hart based host computer or hand held terminal unit are utilized the T798 proves to be a valuable solution. It offers the on line diagnostic functions and calibration certification features employed by a growing number of advanced users. Additionally, the efficiency advantages of PC based range programming can also be realized.

The T797 with easy field programming display option provides a flexible 'off the shelf' solution to the majority of process temperature measurement applications minimizing inventory requirements for spares.

Accurate and stable, both these transmitters can withstand the harsh extremes of the industrial environment. Either mounted in an explosion proof enclosure or wired through intrinsic safety barriers, the T79X series can meet the stringent safety requirements of most hazardous environments.

### CALIBRATION

Trimming of the display and output as well as calibration utilizing an external source is described in the user manual, which is included with each transmitter shipped.

### ASSISTANCE:

For additional information on calibration, operation and installation please contact Technical Services Group. Call toll free:

**800-783-6664**

INPUT RANGES				
sensor input	range	accuracy	range	accuracy
Thermocouple Type B	+212 to +3,272°F	±1.08°F	+100 to 1,800°C	±0.6°C
Thermocouple Type C	+32 to +4,208°F	±0.9°F	+0 to 2,320°C	±0.5°C
Thermocouple Type E	-58 to +1,832°F	±0.36°F	+50 to 1,000°C	±0.2°C
Thermocouple Type J	-292 to +1,382°F	±0.36°F	-180 to 750°C	±0.2°C
Thermocouple Type K	-292 to +2,282°F	±0.36°F	-180 to 1,250°C	±0.2°C
Thermocouple Type L	-328 to +1,652°F	±0.72°F	-200 to 900°C	±0.4°C
Thermocouple Type N	+32 to +2,192°F	±0.36°F	0 to 1,200°C	±0.2°C
Thermocouple Type R	+32 to +2,912°F	±0.9°F	0 to 1,600°C	±0.5°C
Thermocouple Type S	+32 to +2,822°F	±0.9°F	0 to 1,550°C	±0.5°C
Thermocouple Type T	-238 to +752°F	±0.54°F	-150 to +400°C	±0.3°C
Thermocouple Type U	-148 to +1,112°F	±0.72°F	-100 to +600°C	±0.4°C
100W Platinum RTD DIN Curve ( $\mu = 0.00385$ )	-328 to +1,562°F	±0.14°F	-200 to +850°C	±0.08°C
100W Platinum RTD SAMA Curve ( $\mu = 0.003923$ )	-328 to +1,193°F	±0.14°F	-200 to +645°C	±0.08°C
Call Factory for 100W Ni, 120W Ni, and 10W Cu				
Millivolt	-15 to 115mV	±0.006mV		
Ohm	0 to 500W	±0.002W		

## SPECIFICATIONS

<b>Linearization:</b>	Thermocouple and RTD linearization to $\pm 0.05^{\circ}\text{C}$ . Custom linearization with 22 point curve (consult factory).
<b>Input Impedance:</b>	Greater than 1 MW
<b>Output:</b>	Analog, Two-wire 4 to 20mA
<b>Transmitter</b>	
<b>Accuracy:</b>	$\pm 0.05\%$ of the millivolt or ohm equivalent input reading, or the value from the Accuracy Table, whichever is greater; plus $\pm 0.05\%$ of the span. For thermocouples, add $\pm 0.5^{\circ}\text{C}$ ( $0.9^{\circ}\text{F}$ ) for cold junction effect.

*Accuracy includes transmitter repeatability, hysteresis and linearity as well as ambient temperature effect. A/D conversion error, analog output error, line voltage effects, humidity effect under non-condensing conditions and vibration effect to 2g's & 500 Hz.*

<b>Transmitter</b>	
<b>Repeatability:</b>	One-half the transmitter accuracy
<b>Cold-Junction</b>	
<b>Compensation:</b>	Digital self-correcting over the ambient temperature range to within $\pm 0.5^{\circ}\text{C}$
<b>Output Ranging</b>	
<b>Adjustments:</b>	Analog Zero: 100% of Sensor range — Non-interacting Analog Full-scale: Normal or Reverse Acting
<b>Ambient Temperature</b>	
<b>Stability:</b>	Self-correcting over the operating temperature range
<b>Long Term Stability:</b>	Stability deviation per year is less than: (0.025% of output the span $\pm 0.05\%$ of the reading)
<b>Damping:</b>	Factory selectable constant (63%) from 0 to 32 sec.
<b>Failsafe:</b>	user settable to 3.6 or 23mA

### Operating Temperature Range:

<b>Electronics:</b>	$-40^{\circ}\text{C}$ to $+85^{\circ}\text{C}$ , $-40^{\circ}\text{F}$ to $+185^{\circ}\text{F}$
<b>Display (full visibility):</b>	$-20^{\circ}\text{C}$ to $+70^{\circ}\text{C}$ , $-4^{\circ}\text{F}$ to $+158^{\circ}\text{F}$
<b>Display (with reduced visibility):</b>	$-40^{\circ}\text{C}$ to $+85^{\circ}\text{C}$ , $-40^{\circ}\text{F}$ to $+185^{\circ}\text{F}$
<b>Storage Temperature Range:</b>	$-50^{\circ}\text{C}$ to $+85^{\circ}\text{C}$ , $-58^{\circ}\text{F}$ to $+185^{\circ}\text{F}$

### General:

<b>Mounting Position:</b>	No effect on measurement value
<b>Weight:</b>	T787: 6 oz; T79E-O/D: 2 1/2 lbs.; T79E-1: 12 oz.
<b>Isolation:</b>	Input to Output 500VAC
<b>Power Supply:</b>	The transmitter operates on 12 to 42VDC (30VDC for I/S installations) with no load. Transmitter is protected against reverse polarity connection.

<b>Load Limitation:</b>	Loop resistance including optional indicator: $R(KW) = (\text{Supply Voltage} - 12 \text{ VDC}) / (23\text{mA})$
<b>Electromagnetic Compatibility</b>	
<b>(CE Compliance):</b>	Transmitter operates within specification in fields from 20 to 1,000MHz with field strengths to 30V/m. Meets EN 50082-1 Generic Immunity Standard and EN 55011 Compatibility Emissions Standard.
<b>Dynamic Response:</b>	Update Rate: 150 milliseconds (7 timers per second), typical Response to Step Change: 250 milliseconds minimum; 1 second, typical Start-up Time: 7 sec. Operation to specification in less than 30 sec. Ambient Temperature Change: Selfcorrecting for ambient temperature changes up to $20^{\circ}\text{C/hr}$ .
<b>Interchangeability:</b>	Fully interchangeable without field calibration
<b>Hazardous Location</b>	
<b>Certifications:</b>	<b>Explosion Proof:</b> Explosion Proof Housings available with and without windows; CSA and FM approved for Class I, Div I & II, Groups B, C & D; Class II, Div I & II, Groups E, F, & G, Class III and are rated for NEMA 4X and NEMA 7 environments. Nonincendive: Transmitter is CSA and FM rated nonincendive in Class I, Div II, Groups A, B, C & D and Class II, Div I, Groups F & G, and Class III, Div II, CENELEC Ex N IIC T4-T6 certification pending. <b>Intrinsic Safety:</b> The Intrinsically Safe Rated Models T797-1 & T798-1 Transmitters are CSA and FM rated Intrinsically Safe for Class I, Div I, Groups A, B, C & D and Class II, Div I, Groups E, F & G, and Class III, Div I, Installed in accordance with Drawing #732-0220-00 for T797 and #732-0221-00 for T798. CENELEC EEx ia IIC T4-T6 Intrinsically Safe certification pending.

### Standard

<b>Configuration:</b>	<b>Sensor Input:</b> J Type Thermocouple <b>LRV (4mA):</b> $40^{\circ}\text{F}$ Lower Range Value URV (20mA) $200^{\circ}\text{F}$ Upper Range Value <b>Damping:</b> 0 seconds Output Linear with Temperature Failsafe Upscale (23mA)
-----------------------	---

## MOUNTING

DIN Mounting Bracket

**T79A-D**

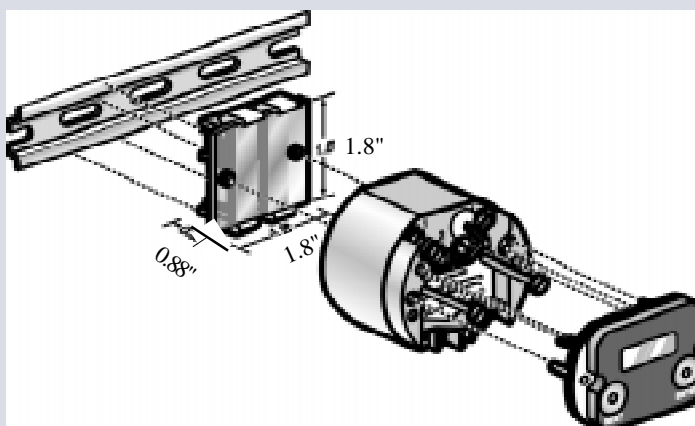

Mounting Bracket

**T79A-P**

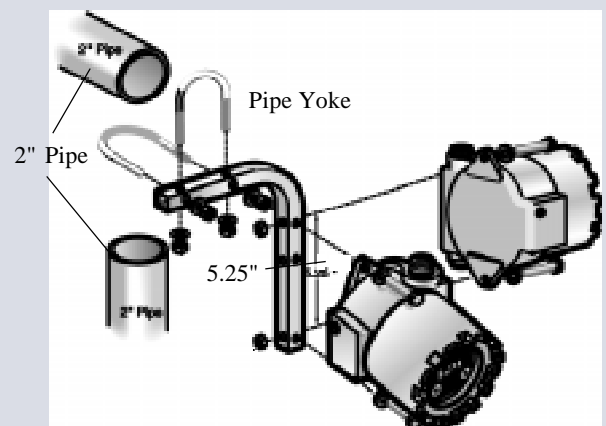

## DIMENSIONS

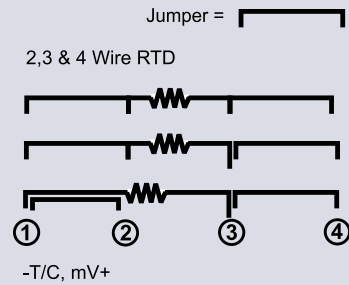
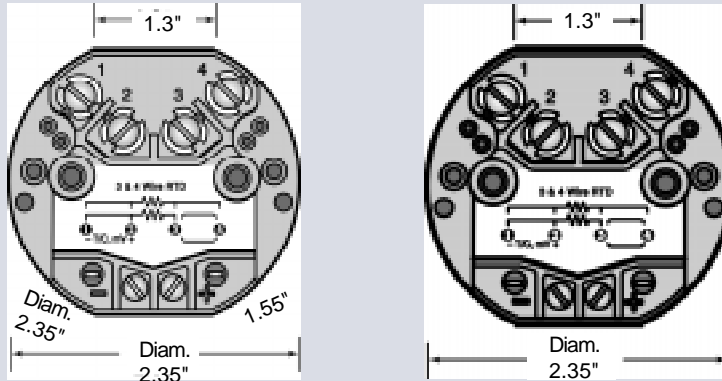

Figure 3: Input Wiring Diagram

## CONNECTIONS

No Barrier

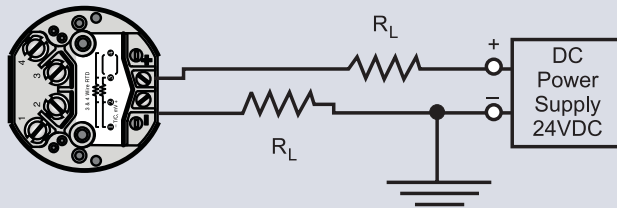

Figure 1: Normal Installation

Hazardous/Barrier

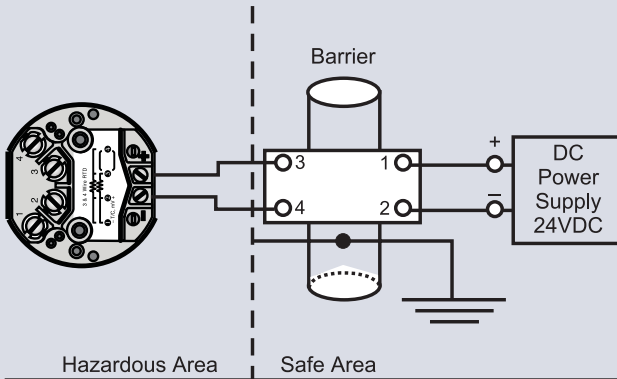
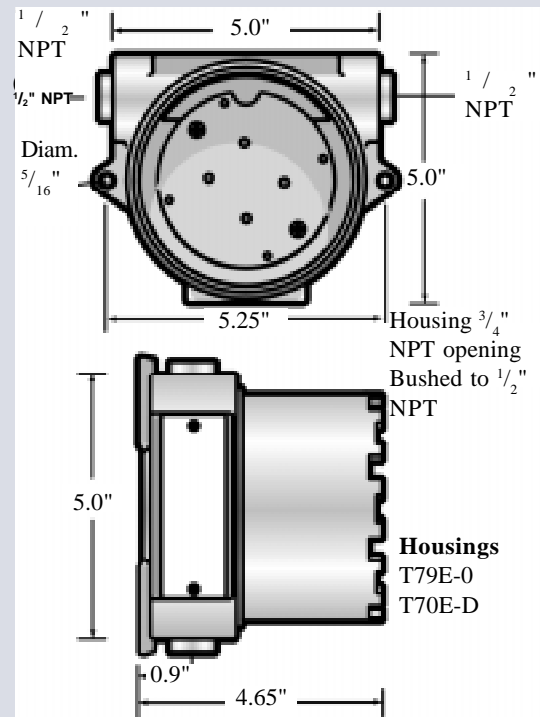

Figure 2: Intrinsically Safe Installation

## ENCLOSURES

Explosion Proof Housing



Note: Allow 5.65" for cover removal

## MODELS & ACCESSORIES

### Models Transmitters

T797-0000	Temperature Transmitter, Non IS
T797-1000	Temperature Transmitter, IS-FM/CSA
T797-2000	Temperature Transmitter, IS-CENELEC
T798-0000	Temperature Transmitter, Hart, Non IS
T798-1000	Temperature Transmitter, Hart, IS-FM/CSA
T798-2000	Temperature Transmitter, Hart, IS-CENELEC

### Ordering Information

- Specify (model number)
- 1) Transmitter Model: **T79X-XXXX**
  - 2) Optional Display, Configuration Modem, Software:
  - 3) Optional Enclosure:
  - 4) Optional Enclosure Mounting:
  - 5) Optional Factory Configuration: Specify model **C620** and desired configuration

### Models Displays & Options

T79D-2000	Two Line Alphanumeric Display
T79D-1000	One line alpha-numeric Display
T79E-D000	Explosion Proof Housing w/ Window
T79E-0000	Explosion Proof Housing w/out Window
T79E-1000	Weather Proof Head-Mount Enclosure
T79E-H000	Explosion Proof Head-Mount Enclosure
T79A-P000	Pipe Mount Bracket for T79E-0/D only
T79A-B000	Bulkhead (flat surface) Mounting Plate
T79A-D000	DIN Rail Mounting Kit
T79A-M000	T797 Configuration Modem
T79A-MH00	T798 Hart Configuration Modem
T79A-C000	Configuration Software for T797 & T798
T79A-E000	Mounting Kit for EP Enclosure

**Eurotherm Action, Inc.**  
**Action Instruments**

8601 Aero Drive  
858-279-5726  
sales@actionio.com

San Diego, CA 92123  
Service and support: 800-767-5726  
literature@actionio.com

**www.eurothermaction.com**  
**www.actionio.com**

FAX: 858-279-6290  
support@actionio.com

