



Formerly EIT Gas Detection Systems

UNIVERSAL GAS TRANSMITTER

The Series 4600 Gas^{PLUS} is a toxic gas and oxygen transmitter designed for single and multi-point monitoring applications where ruggedness, flexibility, and ease of maintenance are critical. The basic Series 4600 transmitter is a two-wire device providing a 4-20 mA output. For additional output flexibility, Series 4600 MB transmitters offer RS-485/232 MODBUS[®] RTU output and relay contacts in a multi-wire configuration.

Principle of Operation

Each Gas^{PLUS} uses a proprietary, highly stable, Scott-Bacharach manufactured electrochemical sensor to detect a specific toxic gas or oxygen. Gas diffuses into the sensor and is reduced or oxidized, which creates a current. Microprocessor-based electronics convert this current into gas concentration. Sensor output is linear since the number of electrons given off is proportional to gas concentration.

Use and Maintenance

The Series 4600 keeps maintenance costs low. The transmitter electronics are "universal," meaning that a single transmitter can accept any Gas^{PLUS} sensor. When the transmitter and sensor are connected, the instrument automatically configures itself by identifying gas type, range, calibration, and alarm setpoints.

All sensor parameters (including calibration) are stored in an EEPROM in the

(Continued...)



Available With
ROCK SOLID
Sensors

Bacharach-EIT GasPLUS Sensor Innovation...



Patented Elastomeric Connector for easy, "no alignment required" connection



Integral lithium battery eliminates sensor warm-up.



On-board electronics retain sensor calibration data, gas type and range, and fault codes. Permits remote maintenance and calibration of sensor.



ROCK SOLID[®] high performance sensor technology with extremely stable zero signal and super fast response to, and recovery from, gas exposure.

Features...

Easy-To-Maintain & Operate

- Local display
- Non-intrusive calibration
- No sensor warm-up time
- Remote sensor maintenance
- Universal transmitter
- Sensor removal without the need to declassify the area
- Patented no-pins sensor connection

Self Diagnostics

- Sensor end-of-life indicator
- Missing sensor indicator

Rugged Design

- Conformally-coated electronics
- Horizontal conduit entries

4600MB Additional Features

- Optional built-in alarm relays
- RS-485/232 MODBUS[®] RTU output
- Security lockout

sensor. A built-in lithium battery keeps the sensor “hot,” which eliminates the need for warm-up time and enables users to maintain and calibrate the sensor away from the instrument.

The Gas^{PLUS} includes a built-in intrinsically-safe barrier so the sensor can be removed without declassifying the area. The sensor connects to the transmitter with an elastomeric pad, rather than pins or plugs. This patented design makes sensor replacement quick and easy — even with gloves on.

Multiple self-diagnostics add reliability and security. The sensor end-of-life indicator provides a warning when sensor lifetime is nearing its end. The missing sensor indicator drives instrument output to a fault level if the electrical connection between the sensor and transmitter is broken. Other diagnostics continuously check electronics and software

Operation of the instrument is simple and intuitive and does not require a costly infrared tool. A magnet is simply touched to the front panel for non-intrusive operation and calibration. The local output inhibit (with adjustable output signal) permits true one-man calibration.

4600MB for Optimum Operational Flexibility

The 4600MB offers additional output flexibility and features in a multi-wire configuration. The 4600MB provides, as standard, 4-20mA analog output as well as digital output via RS-485/232 wiring configuration utilizing the MODBUS RTU protocol.

As an option, the 4600MB can be equipped with three on-board relays providing two concentration and one fail relay contacts. These 5A SPST relays come with a programmable time delay to reduce nuisance activations. The programmable relay includes configurable alarm setpoints, time delay on/off, latching/non-latching mode, energized/de-energized mode, alarm reset, and rising/falling relay activation. All parameters are adjusted non-intrusively.

Dimensions

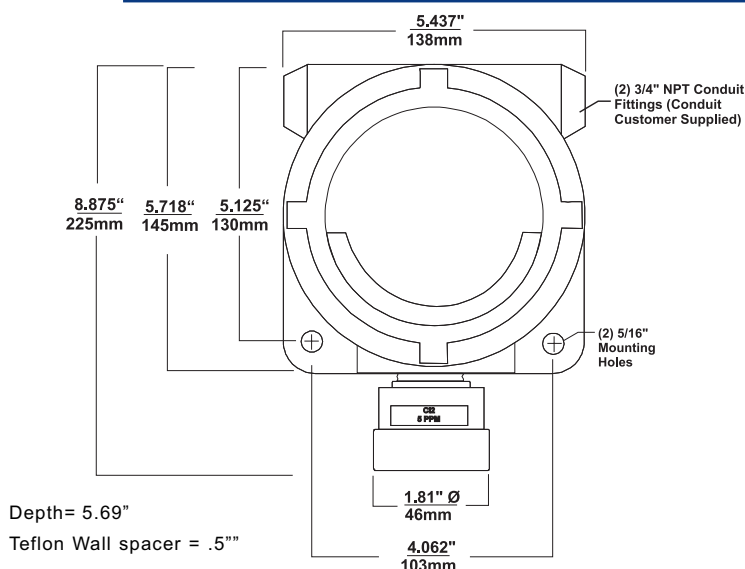

Typical Specifications

1. General. Transmitter shall be housed in a copper free cast aluminum enclosure, with stainless-steel sensor housing that incorporates a zener barrier for intrinsically safe sensor connection. Transmitter and sensor shall be NRTL approved for Class 1, Division 1, Group B, C, and D hazardous locations. Sensor housing and sensor shall be capable of being mounted up to 50 feet from transmitter.

2. Display. Transmitter shall incorporate a 3.5 digit LCD display showing gas concentration, engineering units, alarms status, inhibit status, and weak sensor.

3. Temperature and Power. Transmitter shall operate over an input range of 14-30 VDC. Transmitter shall be two-wire loop-powered device if no on-board relays are used. Maximum loop load shall be at least 450 ohms in two-wire configuration and 750 ohms in three-wire configuration.

4. Output. Transmitter shall provide a linear 4-20mA signal, two optional 5A SPST alarm relays, and one optional 5A SPST fail relay. Alarm setpoint levels shall be adjustable non-intrusively through transmitter's front panel using magnetic screwdriver. An optional RS-485 RTU output shall be available.

5. Calibration. Zero and span calibration shall be performed non-intrusively through transmitter's front panel using magnetic screwdriver. Transmitter shall inhibit output during calibration. A time-out feature shall automatically return the unit to normal operation mode after a preset period of time. Inhibit output level shall be user-selectable. Sensor shall incorporate a lithium battery and electronics to permit off-site calibration.

6. Diagnostics. Instrument shall provide an indication of remaining sensor life after span calibration, and shall indicate a weak sensor on the LCD display. If the sensor is removed while the instrument is powered, output shall drop to 3.5mA to indicate a missing sensor.

7. Sensor. Sensor shall be membraned, amperometric, electrochemical cell-type requiring no sample pumps or replacement of membranes and/or electrolyte. Linearity and repeatability shall both be $\pm 2\%$ of full-scale. Sensor replacement shall not require the alignment of pins, twist-locks, or other easily-damaged connectors.

8. Calibration Program. Manufacturer shall provide optional factory calibration service for all sensors on a quarterly basis. Documentation for each sensor's calibration shall be provided.

Ordering Information

Model 46AA - BB- C- D - E

AA- Gas

A Green color prefix indicates that a Low %RH version is available

A Red color prefix indicates that a High %RH version is available

RS = Rock Solid Sensor

Bold = standard range / see Option "BB"= range options)

- 85 • Ammonia (NH₃) (0-50, **100**, 150, 250, 500) PPM
- 65 • Arsine (AsH₃) (0-**1000 PPB**, 3, 10) PPM
- n/a • Boron Trichloride (BCl₃) **Order HCl sensor**
- 98 • **RS** Bromine (Br₂) **Rock Solid**® (0-1, 3, 5, 10, 15, 25, 30) PPM
- 61 • Bromine (Br₂) (0-1, 3, 5, 10, 15, 25, 30, 50, 100) PPM
- 82 • Carbon Monoxide (0-50, **100**, 150, 200, 250, 300, 500, 1000) PPM
- 22 • **RS** Chlorine (Cl₂) **Rock Solid**® (0-1, 3, **5**, 10, 15, 25, 30) PPM
- 52 • Chlorine (Cl₂) (0-1, 3, **5**, 10, 15, 25, 30, 50, 100, 200) PPM
- 57 • **RS** Chlorine Dioxide **Rock Solid**® (0-1, 3, 5, 10, 15) PPM
- 53 • Chlorine Dioxide (ClO₂) (0-1, 3, 5, 10, 15, 25, 30, 50, 100) PPM
- n/a • Dichlorosilane (SiH₂Cl₂) - **Order HCl sensor**
- 67 • Diborane (B₂H₆) (0-**1000 PPB**, 2, 10) PPM
- 62 • Fluorine (F₂) (0-1, 3, 5, 10, 15, 25, 30, 50, 100) PPM
- 69 • Germane (GeH₄) (0-**1000 PPB**, 3, 10) PPM
- 87 • Hydrogen (H₂) (0-1%, **4%**, 5%, 10%)
- 94 • **RS** Hydrogen Bromide **Rock Solid**® (0-1, 3, **5**, 10, 15, 20, 25, 30) PPM
- 92 • **RS** Hydrogen Chloride **Rock Solid**® (0-1, 3, 5, 10, 15, 2, 0, **25**, 30) PPM
- 71 • Hydrogen Chloride (HCl) (0-10, **25**, 50, 100) PPM
- 64 • Hydrogen Cyanide (HCN) (0-10, **25**, 30, 50, 100) PPM
- 90 • **RS** Hydrogen Fluoride (HF) **Rock Solid**® (0-1, 3, 5, **10**, 15, 25, 30) PPM
- 63 • Hydrogen Fluoride (HF) (0-10, 15, 25, 50, 100) PPM
- 89 • Hydrogen Selenide (H₂Se) (0-**1000 PPB**, 10) PPM
- 81 • Hydrogen Sulfide (H₂S) (0-10, 25, **50**, 100, 200) PPM
- 59 • Methanol (CH₃OH) (0-**500**) PPM
- 44 • Methyl Iodide (CH₃I) (0-**25**) PPM
- 34(P) • Methylene Chloride (CH₂Cl₂) (0-**200**) PPM
- 86 • Nitric Oxide (NO) (0-25, **50**, 100, 500) PPM
- 84 • Nitrogen Dioxide (NO₂) (0-**10**, 25, 50, 100, 250) PPM
- 33(P) • Nitrogen Trifluoride (NF₃) (0-10) PPM
- 80 • Oxygen (O₂) (0-10%, **25%**)
- 60 • Ozone (O₃) (0-1, 2, 3, 5, 10, 15, 25, 30, 50, 100) PPM
- 66 • Phosphine (PH₃) (0-**1000 PPB**, 3, 10) PPM
- 68 • Silane (SiH₄) (0-1000 PPB, 0-**10** PPM)
- 96 • **RS** Sulfur Dioxide (SO₂) **Rock Solid**® (0-3, 5, **10**, 15, 25, 50, 30) PPM
- 83 • Sulfur Dioxide (SO₂) (0-**10**, 15, 25, 50, 100, 500) PPM

BB- Ranges Selection

05	0-1 PPM	35	0-20 PPM	65	0-200 PPM	1 C	0-1%
10	0-2 PPM	40	0-25 PPM	70	0-250 PPM	1 D	0-4%
15	0-3 PPM	45	0-30 PPM	75	0-300 PPM	1 E	0-5%
20	0-5 PPM	50	0-50 PPM	80	0-500 PPM	1 F	0-10%
25	0-10 PPM	55	0-100 PPM	85	0-1000 PPM	1 G	0-25%
30	0-15 PPM	60	0-150 PPM	1 B	0-1000 PPB		

C - Sensor Connection / Housing

- 1 - Integral Sensor with transmitter
- 2 - Separated Sensor w/ junction box and 50' cable
- 3 - Separated Sensor, no J-box 6' cable standard
- 4 - Condensing Humidity Sensor housing, no window/includes Humishield End Cap

D - Transmitter Output

Series 4600

- 1 - Standard (4-20 mAdc)
- 2 - Local Relays Normally Open (qty3)
(EXISTING INSTALLATIONS ONLY!)
- 3 - Local Relays Normally Closed (qty3)
(EXISTING INSTALLATIONS ONLY!)

Series 4600MB

- 4 - 4600MB (RS-485, 4-20mA) without Relays (qty3)
- 5 - 4600MB (RS-485, 4-20mA) Local Relays N.O. (Low, High, Fault)
- 6 - 4600MB (RS-485, 4-20mA) Local Relays N.C. (Low, High, Fault)

The stated relay configuration (NO/NC) assumes gas concentration relays to be field programmed as Non-FAILSAFE. Programming for failsafe reverses the NO/NC operation.

E - Adaptors

- 1 - No Adaptors
- 2 - 1/4 Turn Rainshield/Splash Guard (typical)
- 3 - Combined S.S. Rainshield/Cal Adaptor w/ SS End Cap (for REMOTE sensor applications)
- 4 - 1/4 Flowcell

ACCESSORIES

Part #	Description
096-2101	1/4 turn Calibration Cup
096-2197	Gas Plus Sensor Keeper - prevents battery drain on up to 10 sensors.
096-2146	Condensing Humidity Membrane (for Humishield) QTY 5 (H ₂ S only)
096-2113	24Vdc Power Supply in NEMA-4X heated enclosure.
096-2104	Dust Filter (H ₂ S, O ₂ , and CO ONLY) bag of 10
096-2140	Isopropyl Alcohol Filter (hydride sensors only)
096-2141	Hydrogen Sulfide Filter (Pack of 5) (HCN, NH ₃ , and hydride sensors only)
096-2118-F	Flat duct mount adaptor
096-2118-6/8	Round duct adaptor for 6" to 8" ducts

4600 Electrical Connections

Power Only

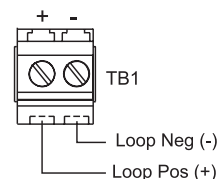

4600-MB Electrical Connections

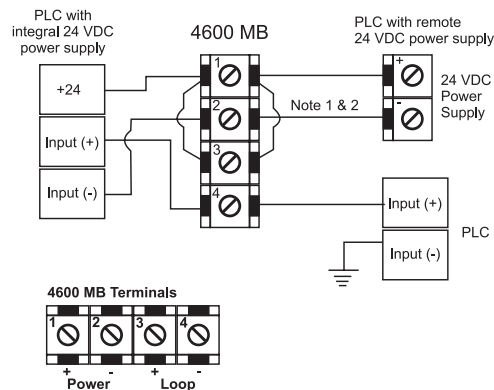

NOTES:
1- Power supply common (c) is connected to earth ground within the transmitter.
2- The 4600MB 24 VDC negative/common is referenced to earth ground in order to maintain the internal sensor I.S. Barrier certification.

Alarm Relay Connections

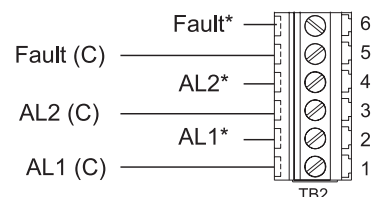

The stated relay configuration (NO/NC) assumes gas concentration relays to be field programmed as Non-FAILSAFE. Programming for failsafe reverses the NO/NC operation.

Specifications

All specifications shown apply to both Series 4600 and Series 4600MB unless otherwise noted.

Enclosure	<i>Transmitter:</i> Copper-free cast aluminum.
	<i>Sensor housing:</i> Stainless steel with PVC end-cap
Temperature Range	<i>Transmitter:</i> -40°F to 140°F (-40°C to 60°C)
	<i>Sensor:</i> Depends on gas type. See Gas Capabilities Data Sheet
Operating Humidity Range	Up to 99%RH, non-condensing (up to 100%RH with optional humishield)
Operating Pressure Range	0-10psig
Weight	5lbs (2.25Kg)
Power Requirements	(4600 2 wire): 14-30 Vdc 0.6W (4600MB 3 wire): 18-30 Vdc 1.2 W (4600MB w/ relays): 18-30 VDC 2.0W
Output	<i>Analog:</i> 4-20mA (4600MB) RS-485/232 Modbus RTU (4600MB w/Relay): 2 alarm, 1 fail (all 5A SPST rated at 120V); user-selectable latching/non-latching and energized/de-energized
Maximum Loop Load	(4600 2 wire): 460 ohm at 24VDC (4600MB w/relays): 950ohm at 24VDC
Display	3.5 digit LCD; 0-100% bargraph; alarm indication; inhibit indication; weak sensor indication.
Local Inhibit Output	Selectable (4600): 3.5 to 20.0 mA (4600MB): 0-20 mA
Self-diagnostics	Weak sensor; Missing sensor; transmitter fault
Max. Sensor Separation	50 feet (15.25m) from transmitter
Sensor Type	Electrochemical gas diffusion
Sensor Life	22-24 months average; disposable
Sensor Battery	9 months continuously unpowered (no drain when powered)
Sensor Repeatability	±2% full scale
Sensor linearity	±2% full scale
Approvals	(4600): ETL & UL/C-UL Class I, Division 1, Groups B, C, D (4600MB): UL/C-UL Class I, Division 1, Groups B, C, D / CENELEC/CSA/ Approvals pending
Warranty	1 year (sensor and transmitter)

1/4 Turn Accessories

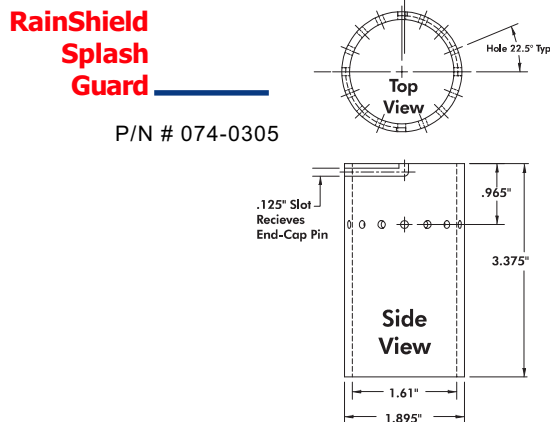
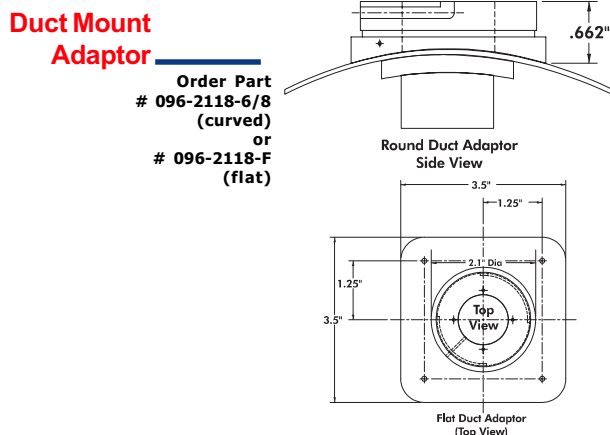
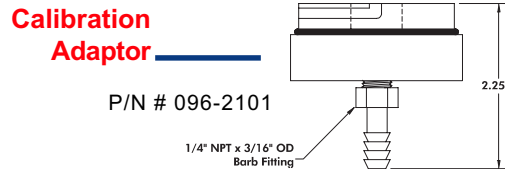
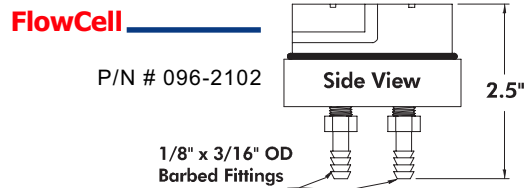

Represented by: Omni Controls Inc.

800-783-6664